

Ophthalmic Prisms

Measurement Errors and How to Minimize Them

JOHN T. THOMPSON, MD, DAVID L. GUYTON, MD

Abstract: Variable results of strabismus surgery may be due in part to errors in prism measurement. The amount of deviation neutralized by an ophthalmic prism is variable depending on how the prism is held. For example, a 40^Δ glass prism with the posterior face held in the frontal plane gives only 32^Δ of effect. Glass prisms are calibrated for use in the Prentice position. Plastic prisms are calibrated for use in the frontal plane position. Surprisingly large errors in prism measurement are produced when adding a small prism to a large prism. For example, adding a 5^Δ glass prism to a 40^Δ glass prism gives not 45^Δ of effect, but 59^Δ. This error can be minimized but not eliminated by holding one prism in front of each eye. The error can also be calculated so that the appropriate correction can be made. [Key words: deviation, measurement error, ophthalmic prisms, prism addition, prism calibration, prisms, strabismus.] *Ophthalmology* 90:204-210, 1983

Variable results in strabismus surgery may be partly due to errors in the measurement of strabismic deviations by ophthalmic prisms. The prismatic deviation of a given ophthalmic prism is dependent on the angular position of the prism as it is held before the patient's eye. This source of error was recognized by Prentice when he proposed the use of the unit "prism diopter."¹ Several investigators have described the effect of various prism positions on the deviation measured.²⁻⁴ Errors in prism measurement will occur if a prism is used in a position for which it is not calibrated. Most glass prisms, for example, are calibrated for use in a position different from that of plastic prisms.

Another major source of error arises from the common practice of adding or stacking two prisms together in the same direction to measure large strabismic deviations. Bicas has described the mathematics of the addition of two prisms.⁵ The present study investigates

these sources of error in prism measurement and proposes methods to minimize them. Accurate and reproducible measurements are obviously a prerequisite for improving the results of strabismus surgery.

HOLDING PRISMS CORRECTLY

The deviation produced, or neutralized, by a prism is dependent on the position of the prism as it is held before the patient. There are three commonly used positions for holding ophthalmic prisms (Fig 1). The first position is the **Prentice position**. In this position the posterior face of the prism is perpendicular to the line of sight of the deviating eye. All of the prismatic deviation occurs at the anterior face of the prism. (Note that the same amount of deviation will occur if the *anterior* face is perpendicular to the light rays entering the anterior face of the prism.) The second position is the **position of minimum deviation**. In this position the same prismatic deviation occurs symmetrically at each of the two faces. In other words, the visual axis inside the prism is perpendicular to the line bisecting the apex angle of the prism. The third position we call the **frontal plane position**. The posterior face of the prism is held in the frontal plane of the patient.

From The Wilmer Ophthalmological Institute, The Johns Hopkins University School of Medicine, Baltimore, Maryland.

Presented at the Eighty-seventh Annual Meeting of the American Academy of Ophthalmology, San Francisco, California, October 30-November 5, 1982.

Reprint requests to David L. Guyton, MD, Wilmer B1-35, Johns Hopkins Hospital, Baltimore, MD 21205.

Fig 1
sition
prism
tion.
viatic
fronte

W
thopi
meas
lies b
aware
meas
Figur

80
70
60
50
40
30
DEVIATION IN PRISM DIOPTERS

—
—
—

This
holdin

Fig 2. 7.
function
the norm
for each

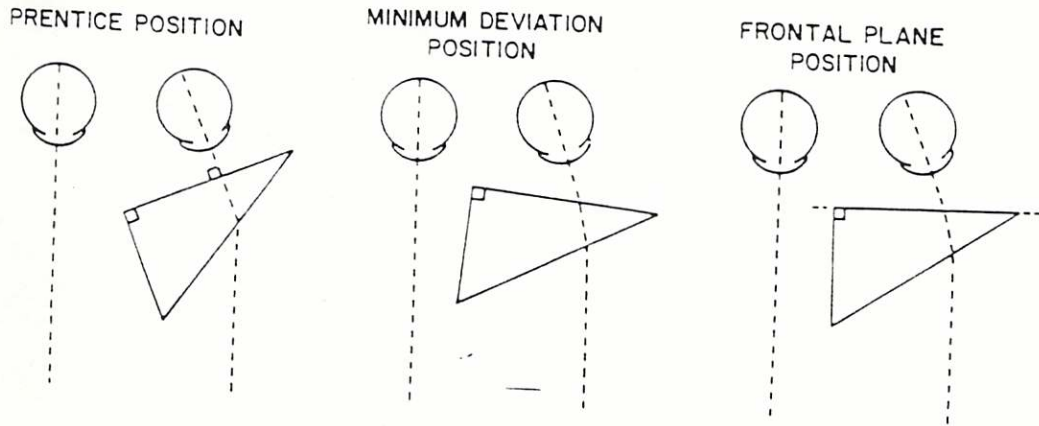

Fig 1. Three common positions for ophthalmic prisms. *Left.* Prentice position. *Center.* minimum deviation position. *Right.* frontal plane position.

We have observed both ophthalmologists and orthoptists using each of the three positions for prism measurement. Some hold the prism in a position that lies between two of these positions, and many are unaware that it makes a difference. The prismatic deviation measured with each of these three positions is different. Figure 2 shows a plot of the deviation in prism diopters

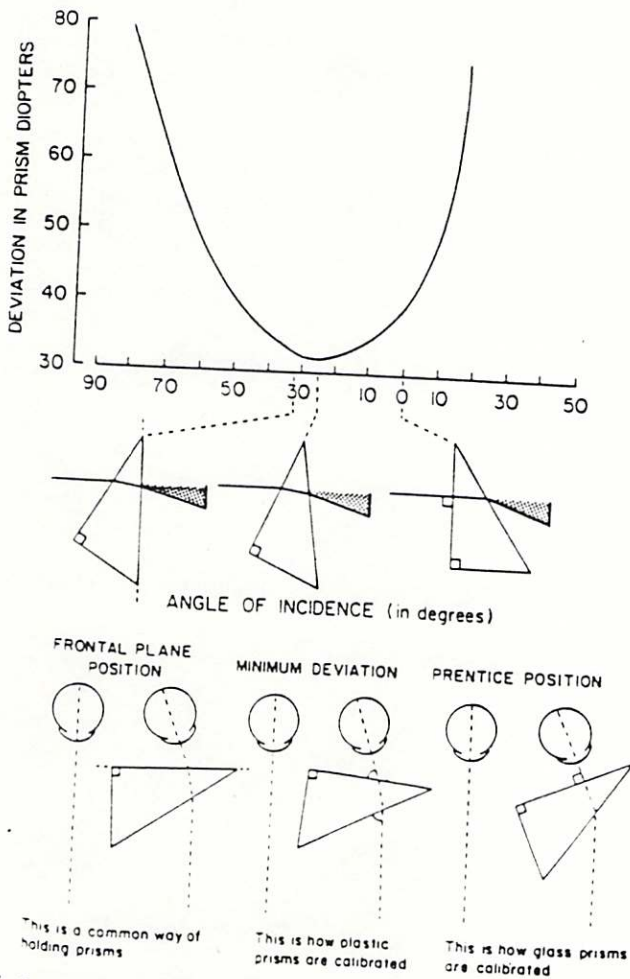

Fig 2. *Top.* the deviation in prism diopters of a 40^Δ glass prism as a function of the angle of incidence of the incident ray (measured from the normal to the surface). *Bottom.* the corresponding prism position for each of the three angles of incidence marked on the upper graph.

vs the angle of incidence in degrees for a 40^Δ glass prism. The prism positions corresponding to selected angles of incidence are also shown at the bottom of Figure 2. It is apparent that the deviation in the position of minimal deviation is very close to the deviation in the frontal plane position (the difference between these two positions is never greater than 2^Δ with available glass or plastic prisms). The deviation in the Prentice position, though, is much larger than in the position of minimum deviation (40^Δ vs 32^Δ). Also note that because the deviation in the Prentice position falls on the slope of the curve, small changes from the Prentice position produce relatively large changes in deviation. The deviations in the other two positions change much less with small changes in position, because these positions are at or near the trough of the curve.

The deviation difference between the Prentice and minimum deviation positions is small for prism values less than 20^Δ but increases significantly for large prisms. Figure 3 shows a graph of the deviation in prism diopters vs the labeled value of glass prisms held in both the Prentice position and the frontal plane position. If a 40^Δ glass prism is held in the Prentice position, the resulting

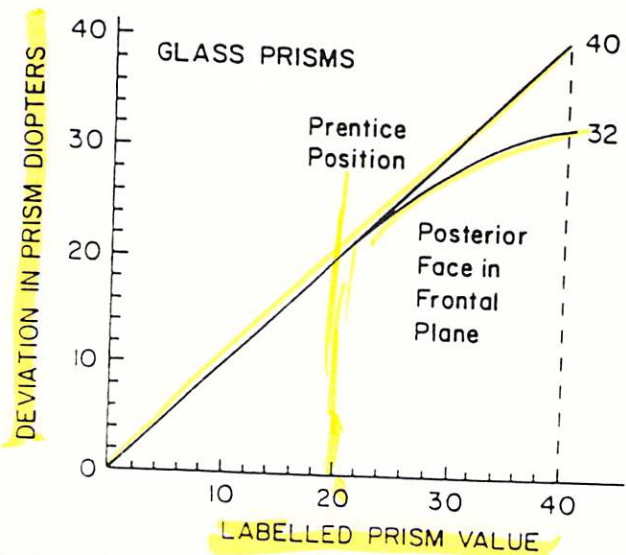

Fig 3. The deviation in prism diopters versus the labeled value of glass prisms held in the Prentice and frontal plane positions.

deviation is 40^Δ . If the same 40^Δ glass prism is held in the frontal plane position, the resulting deviation is only 32^Δ . This graph reflects the fact that the glass prisms we measured are calibrated for use in the Prentice position. This is not the case for the more commonly available plastic ophthalmic prisms (Berens prisms manufactured by Gulden), which are calibrated for use in the position of minimum deviation as stated by the manufacturer.⁹ Figure 4 shows a plot of the deviation in prism diopters vs the labeled value of plastic prisms held in both the Prentice position and the frontal plane position. If a 40^Δ plastic prism is held in the Prentice position, the result is 72^Δ of deviation. If the same 40^Δ plastic prism is held in the frontal plane position, the result is 41^Δ of deviation. The deviation in the frontal plane position is 1^Δ greater than the deviation in the position of minimum deviation for a 40^Δ plastic prism.

The frontal plane position appears to be the best practical way to hold a plastic ophthalmic prism, for the position of minimum deviation may be quite difficult to judge in clinical practice. Plastic prisms of less than 25^Δ have right angle bases, and prisms of 25^Δ and up have isosceles bases. Note that the shape of the base has nothing to do with the way the prism is calibrated or how it should be held. Horizontal and vertical plastic prism bars (Gulden) are calibrated for use in the frontal

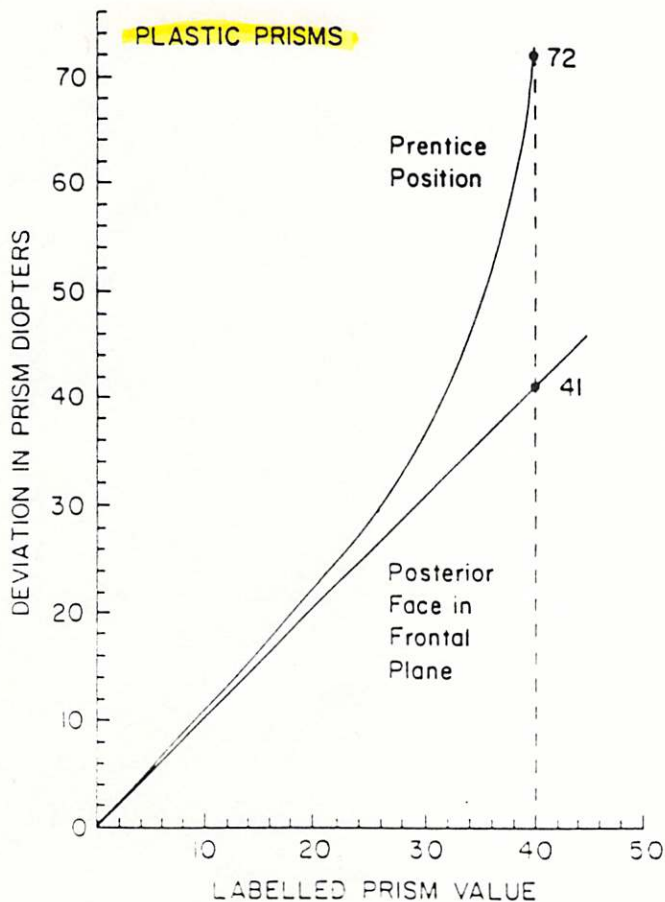

Fig 4. The deviation in prism diopters versus the labeled value of plastic prisms held in the Prentice and frontal plane positions.

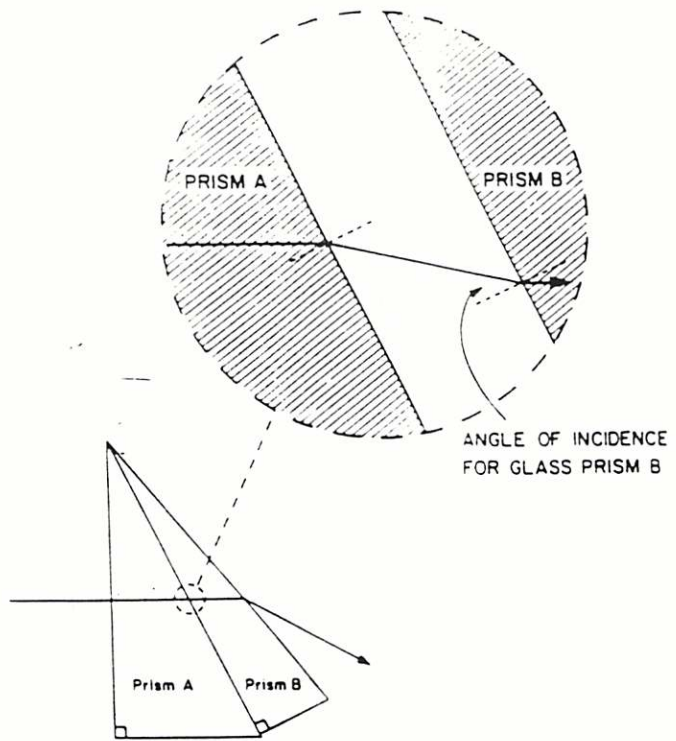

Fig 5. The path of light through two glass prisms stacked together. The ray enters prism A in the calibrated position but enters prism B far from the calibrated position.

plane position, that is, with the flat side of the bar held posteriorly, parallel to the frontal plane of the patient.

The frontal plane position is appropriate for holding plastic prisms when measuring distance deviations. When measuring deviations at near, the rear surface of the plastic prism should still be held perpendicular to the line of sight anterior to the prism, but this necessitates rotating the rear surface of the prism out of the frontal plane of the patient.

ADDING PRISMS

It is a common technique in strabismus to stack two prisms in the same direction to measure a large deviation or a deviation that is between the calibrated values of two prisms in a set. (Glass prisms are available to a maximum of 40^Δ , and plastic prisms are available to a maximum of 50^Δ .) This practice of adding prisms in the same direction can lead to significant errors in measurement. The key to this source of error lies at the interface between the two prisms. Figure 5 shows an enlarged diagram of the path of light through two glass prisms stacked together. The ray enters the first glass prism in the Prentice position, which is the calibrated position for glass prisms. The ray crossing the interface and entering the second prism, however, enters at a much greater angle than the calibrated angle of incidence, and hence the second prism will produce a significantly larger deviation than indicated by its labeled

ME
F

Fig
tio

va
th
by
of
wi
th
an
tic
gl

In
pr
br
th
tw
po
wi
tw

Fig
tio
5
the
an
tio
for

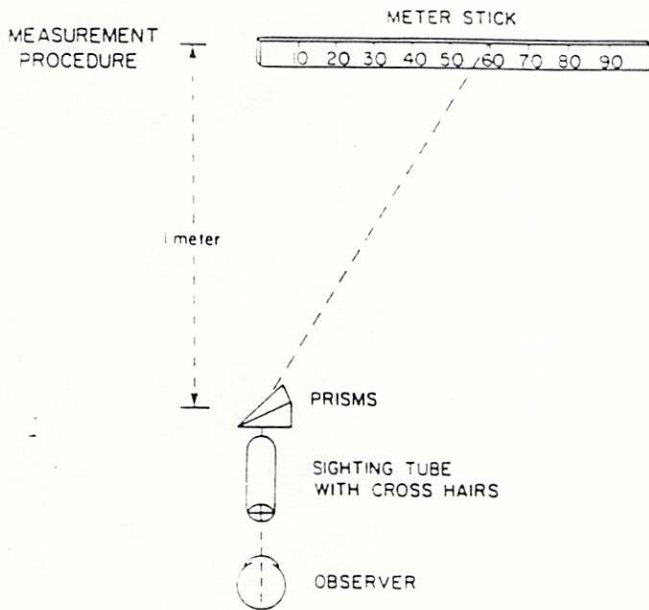

Fig 6. An experimental method for measuring the sum of the deviations of two prisms stacked together.

value. Even if the first glass prism is held at angles other than the Prentice position, the total deviation produced by the two prisms will usually be greater than the sum of the labeled values. Note that it makes no difference whether the smaller prism is held in front of, or behind, the larger prism. It is the total wedge of glass and the angle at which it is held that determine the total deviation; the location of the interface within the wedge of glass is immaterial.

The same analysis can be applied to plastic prisms. In this case, the deviation of the sum of two plastic prisms will always be greater than the sum of the calibrated values. Because plastic prisms are calibrated for the position of minimum deviation, at least one of the two prisms stacked together will have to be out of the position of minimum deviation, and the total deviation will thus be increased.

The deviation of any single prism or combination of two prisms can be derived using Snell's Law. In the case

of two prisms held together in the same direction, the apex angle of the composite prism can be treated similarly to the apex angle of a single prism. This assumption is true if both prisms have the same refractive index and the prism faces at the interface are parallel. There is no net deviation at the interface, with the ray inside the second prism remaining parallel to the ray inside the first prism (Fig 5). The only effect of the interface is to displace the path of the ray very slightly, parallel to itself. Appendix I gives the derived formulas for the deviations of any single prism or combination of prisms held in the Prentice position, position of minimum deviation, and frontal plane position.

Recall that the prism diopter is defined as one centimeter of deviation measured perpendicular to the original light ray, at a distance of one meter. Our calculations can be verified experimentally by placing the single prism, or combination of prisms, exactly 1 M from a horizontal centimeter scale (Fig 6). The prism or combination of prisms is placed in one of the three desired positions, and the deviation is read directly from the centimeter scale sighted through the prism or prisms.

For example, both calculation and experiment confirm (Fig 7) that the addition of a 5^Δ glass prism to a 40^Δ glass prism in the Prentice position does not result in 45^Δ of deviation. Instead, the result is 59^Δ of deviation. If the same two glass prisms are held together with the most posterior face in the frontal plane, the result is only 39^Δ of deviation. If each of the two glass prisms is held in the Prentice position, the total deviation is indeed 45^Δ, but it would obviously be impractical to try to hold the two glass prisms in this position (Fig 7).

The addition of a 5^Δ plastic prism to a 40^Δ plastic prism in the Prentice position results in total internal reflection (Fig 7). The same combination held in the frontal plane position results in 50^Δ of deviation. If each of the two plastic prisms is held in the position of minimum deviation, the total deviation is equal to 45^Δ. Again, though, it would be impractical to try to hold the two plastic prisms in this position (Fig 7).

Calculated and experimental deviations produced by two prisms stacked together are shown in Figures 8 and 9. Figure 8 shows a graph of the deviation in prism

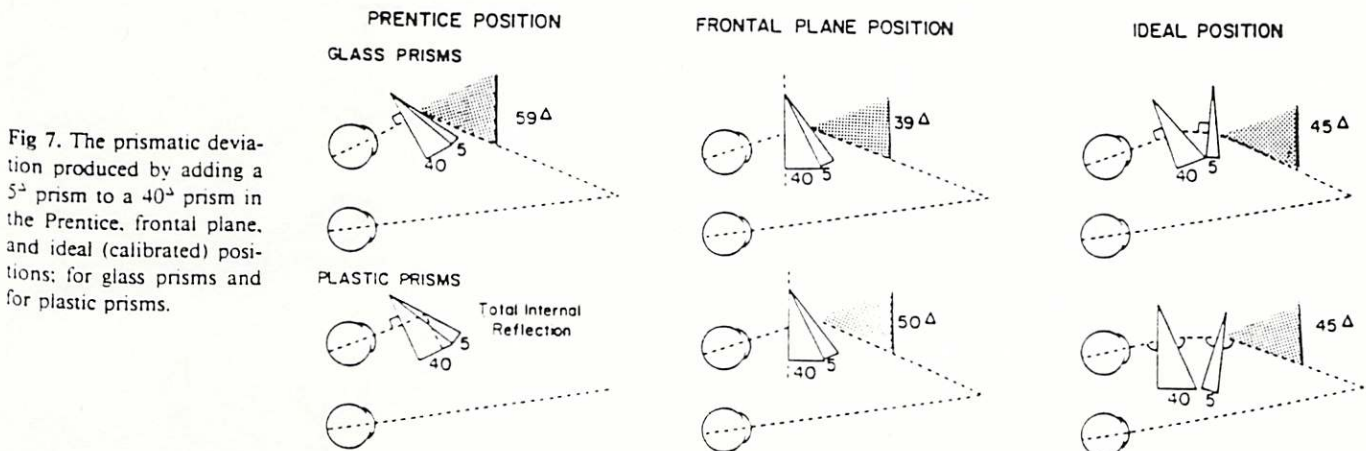

Fig 7. The prismatic deviation produced by adding a 5^Δ prism to a 40^Δ prism in the Prentice, frontal plane, and ideal (calibrated) positions; for glass prisms and for plastic prisms.

GLASS PRISMS - PRENTICE POSITION

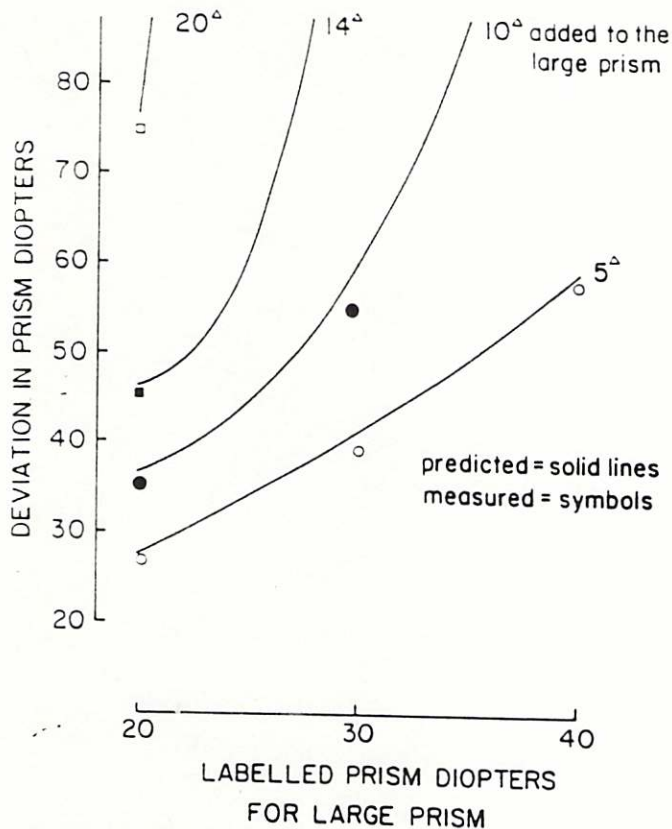

Fig 8. The total deviation in prism diopters produced by adding a 5, 10, 14, or 20^Δ glass prism to a 20, 30, or 40^Δ glass prism in the Prentice position.

PLASTIC PRISMS - FRONTAL PLANE POSITION



Fig 9. The deviation in prism diopters produced by adding a 5, 10, 14, 20, 25, or 30^Δ plastic prism to a 20, 30, 40, or 50^Δ plastic prism in the frontal plane position.

SPLITTING PRISMS BETWEEN THE TWO EYES

It might appear that the problem of nonadditivity of prisms can be avoided by placing one prism in front of

Table 1. Deviation in Prism Diopters for the Addition of Two Plastic Prisms Stacked Together, with the Posterior Prism in the Frontal Plane Position

Added Prism (labeled value in prism diopters)	Initial Prism (labeled value in prism diopters)											
	10	12	14	16	18	20	25	30	35	40	45	50
1	11	13	15	17	19	21	27	32	37	43	48	54
2	12	14	16	18	20	23	28	33	39	45	50	56
3	13	15	17	19	22	24	29	35	40	46	52	58
4	14	16	18	21	23	25	30	36	42	48	54	61
5	15	17	20	22	24	26	32	38	44	50	56	63
6	16	19	21	23	25	27	33	39	45	52	59	66
7	17	20	22	24	26	29	35	41	47	54	61	68
8	19	21	23	25	28	30	36	42	49	56	63	71
9	20	22	24	27	29	31	37	44	51	58	66	74
10	21	23	25	28	30	33	39	46	53	60	68	77
12	23	25	28	30	33	35	42	49	57	65	74	84
14	25	28	30	33	35	38	45	53	61	70	80	91
16	28	30	33	36	38	41	49	57	66	76	87	100
18	30	33	35	38	41	44	52	61	71	82	95	110
20	33	35	38	41	44	47	56	66	76	89	104	122
25	39	42	45	49	52	56	66	78	93	110	133	165
30	46	49	53	57	61	66	78	94	114	141	183	264
35	53	57	61	66	71	76	93	114	144	195	315	—
40	60	65	70	76	82	89	110	141	195	339	—	—
45	68	74	80	87	95	104	133	183	315	—	—	—
50	77	84	91	100	110	122	165	265	—	—	—	—

diopeters when adding a 5^Δ, 10^Δ, 14^Δ, or 20^Δ glass prism to a 20^Δ, 30^Δ, or 40^Δ glass prism in the Prentice position. The deviation when adding two prisms together is non-linear; the addition of two large prisms results in a deviation far greater than the sum of their labelled values.

Figure 9 is a graph of the deviation in prism diopters when adding a 5^Δ, 10^Δ, 14^Δ, 20^Δ, 25^Δ, or 30^Δ plastic prism to a 20^Δ, 30^Δ, 40^Δ, or 50^Δ plastic prism in the frontal plane position. Again, the deviation produced by two large prisms is much greater than the sum of their labelled values. Figure 9 is expanded in tabular form in Table 1 so that one can determine the actual deviation expected with many possible combinations of commonly available plastic prisms held with the posterior prism in the frontal plane position. It is readily apparent that for the larger prisms substantial errors result from adding two prisms together in the same direction.

The additivity error does not occur when adding a vertical prism to a horizontal prism, for the two vector components do not contribute to one another. Thus, no difficulty is encountered when measuring a vertical deviation in combination with a horizontal deviation.

It should be clear from the preceding discussion that there is no simple way to add accurately two prisms in the same direction except by using a table such as Table 1.

Fig 1
the a
Thus
neut

each
sure
exam
eye
bine
from
give
pris
in th
subs
add
from
It
in fr
to th

Tab

Left E-
Prism
(labeled
value

10
12
14
16
18
20
25
30
35
40
45
50

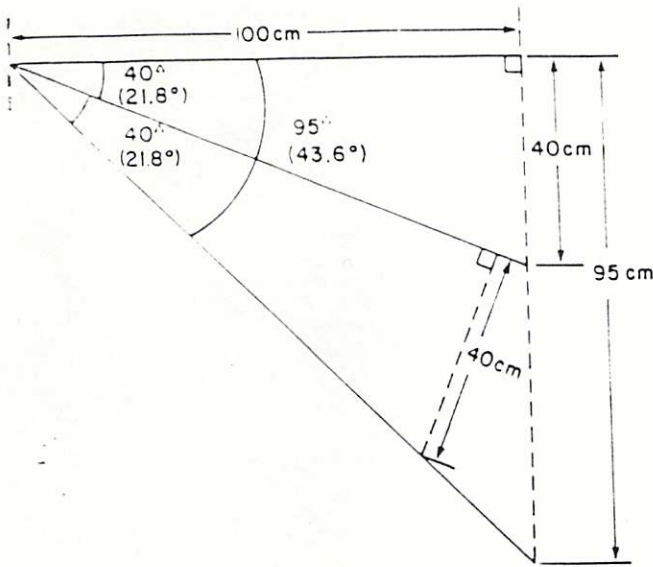

Fig 10. Two equal angles measured in prism diopters do not add to the arithmetic sum of the prism diopter values, but to a larger value. Thus, when one prism is held in front of each eye, the total deviation neutralized is larger than the arithmetic sum of the two labeled prisms.

each eye in the correct position. However, angles measured in prism diopters are not additive (Fig 10). For example, holding one 40^Δ plastic prism in front of each eye neutralizes 95^Δ of deviation. A formula for the combined effect of two prisms when one prism is held in front of each eye is presented in Appendix II. Table 2 gives the combined effect of many possible pairs of prisms (glass or plastic) when held in front of each eye in their calibrated positions. It is clear from Table 2 that substantial errors in prism measurement result when adding the effects of two large prisms with one held in front of each eye.

It must also be remembered that when a prism is held in front of each eye, both eyes are deviated with respect to the fixation target, and the concept of the deviation

Table 2. Deviation in Prism Diopters for the Addition of Two Prisms (Glass or Plastic) with One Prism Held in Front of Each Eye

Left Eye Prism (labeled value)	Right Eye Prism (labeled value)											
	10	12	14	16	18	20	25	30	35	40	45	50
10	20	22	24	26	29	31	36	41	47	52	58	63
12	22	24	26	29	31	33	38	44	49	55	60	66
14	24	26	29	31	33	35	40	46	52	57	63	69
16	26	29	31	33	35	37	43	48	54	60	66	72
18	29	31	33	35	37	39	45	51	57	63	69	75
20	31	33	35	37	39	42	47	53	59	65	71	78
25	36	38	40	43	45	47	53	59	66	72	79	86
30	41	44	46	48	51	53	59	66	73	80	87	94
35	47	49	52	54	57	59	66	73	80	87	95	103
40	52	55	57	60	63	65	72	80	87	95	104	113
45	58	60	63	66	69	71	79	87	95	104	113	123
50	63	66	69	72	75	78	86	94	103	113	123	133

being measured with one or the other eye "fixing" is lost. Only if the deviation is comitant will the true deviation in primary position be measured in this way. Thus, there is in reality no practical way to measure accurately large strabismic deviations with prisms.

SUMMARY

Thus, we must stress the fact that the deviation of a prism is dependent on the angular position of the prism. Single glass prisms are calibrated for use in the Prentice position. Single plastic prisms are calibrated for use in the minimum deviation position that is close to the frontal plane position. Significant errors can result if a prism is held in a position for which it is not calibrated.

The addition of two prisms in the same direction often results in large errors in measurement. If either glass or plastic prisms must be added to one another, the smallest errors will occur if the posterior prism is held in the frontal plane position. The additivity errors of prisms can be reduced but not eliminated by placing one of the prisms in front of each eye.

Careful and accurate measurement of strabismic deviations using the techniques outlined above may indeed help lessen the variability of results in strabismus surgery.

REFERENCES

1. Prentice CF. A metric system of numbering and measuring prisms. Arch Ophthalmol 1890; 19:64-75.
2. Hardy LH, Chace RR, Wheeler MC. Ophthalmic prisms; corrective and metric. Arch Ophthalmol 1945; 33:381-84.
3. Hardy LH. Clinical use of ophthalmic prisms (metric). Arch Ophthalmol 1945; 34:16-23.
4. Bicas HEA. Medidas angulares na rotina oftalmológica: variações do efeito de prismas em função de seus posicionamentos. Rev Bras Oftalmol 1980; 39:5-32.
5. Bicas HEA. Efeitos rotacionais mono e binoculares das associações de prismas. Rev Bras Oftalmol 1980; 39:33-45.
6. R. O Gulden and Co. Ophthalmic Instruments, Catalog. Elkins Park, Pennsylvania.

APPENDIX I

The deviation of any single prism or stacked combination of prisms held in the Prentice position, minimum deviation position, or frontal plane position, is given below. Δ = the total deviation in prism diopters. θ = the total apex angle of the single prism or combination of prisms, and n₂ = the index of refraction of the prism or prisms (glass = 1.523, plastic = 1.49).

DEVIATION WITH PRISM IN PRENTICE POSITION

$$\Delta = 100 \tan [\arcsin (n_2 \sin \theta) - \theta]$$

DEVIATION WITH PRISM IN MINIMUM DEVIATION POSITION

$$\Delta = 100 \tan \left[2 \left[\arcsin \left(n_2 \sin \frac{\theta}{2} \right) \right] - \theta \right]$$

DEVIATION WITH PRISM IN FRONTAL PLANE POSITION

$$\Delta = 100 \tan \left[\arcsin \left[n_2 \sin \left[\theta - \arcsin \left(\frac{\sin \theta}{n_2} \right) \right] \right] \right]$$

APPENDIX II

The deviation when one prism is held in front of each eye is given below. Δ = the total deviation in prism diopters. x and y = the values of the two prisms in prism diopters.

DEVIATION WITH ONE PRISM IN FRONT OF EACH EYE

$$\Delta = 10^4 \left(\frac{x + y}{10^4 - xy} \right)$$